

Modeling PCB Based Inductive Position Sensors With The COMSOL AC/DC Module

Seriem Sid-Ahmed, Lorenzo Lugani

Melexis Technologies SA, Ch. De Buchaux 38, 2022 Bevaix

Abstract

Inductive position sensors rely on a set of coils integrated into a printed circuit board (PCB) and a mobile metallic target. The transmission coil operates at an AC frequency ranging from 2 to 5 MHz and couples with the receiving coils through the target, generating position-dependent voltages used by an interface integrated circuit to reconstruct the target's position.

This paper primarily focuses on predicting sensor inaccuracies due to PCB design-related non-idealities in inductive position sensors through COMSOL simulations. The COMSOL models developed rely on the ECAD Import module to import the exact PCB layout, making possible simulations that closely emulate actual behavior while incorporating necessary physical approximations. The AC/DC module is applied to operate the coils, simulate the eddy currents circulating in the target and to model the interaction between the integrated circuit and the coils. By varying the coils geometry, we identify optimal configurations to enhance sensor accuracy.

Keywords: Inductive sensor, Faraday's Law, Eddy Currents, Magnetic Fields, PCB

Introduction

Position sensors [1] are widely employed in the automotive context. The raise in popularity of electric vehicles has introduced new challenges, as the growing amount of high current cables in these vehicles has increased the exposure of the sensors to stray magnetic fields. Achieving immunity to such stray fields has become a crucial requirement.

Inductive position sensors have emerged as a viable solution due to their inherent immunity to stray magnetic fields [2]. Widespread adoption of the inductive technology is however possible only if these sensors are able to achieve the high accuracy standards (<0.5%) of the automotive industry. To ensure the achievement of optimal performance, realistic simulations of the sensor's electrical behavior are necessary during the design phase.

This paper discusses the use of COMSOL as the tool of choice for the analysis of the factors influencing the accuracy of inductive position sensors. By conducting detailed simulations, we seek to gain valuable insights into the parameters impacting the sensor's performance. The remarkable accuracy of the simulation results enables us to identify the main layout features responsible for sensors inaccuracies, therefore achieving optimal sensor performance while at the same time avoiding long and expensive trial and error experimental iterations.

Inductive position sensors basics

Inductive position sensors (IPS) use Faraday's law of electromagnetic induction by converting changes in magnetic fields into measurable electrical signals. The fundamental idea is to create a changing magnetic field in a coil of wire as the position of the target object changes. The changing position of the object results in a change in the magnetic flux through the coil, which induces a voltage. The PCB design of an IPS is composed of a transmission (Tx) coil and three receiving (Rx) coils that are connected to the interface IC. The design is completed with a metallic target which is attached to the object whose position needs to be sensed. The Tx coil is driven by the interface chip and generates a primary AC magnetic field which excites eddy currents in the target. Such eddy currents generate a secondary AC magnetic field which is picked by the Rx coils generating an induced voltage, which is in turn provided as an input to the IC. The sensors covered by this study make use of three Rx coils in order to allow in the IC a position calculation based on signal ratios, thus removing dependencies from the absolute signal strength. Inside an IC like the MLX90510 [3] or MLX90517, [4] the received signals are filtered, demodulated, amplified and digitized. The target position is digitally calculated on the basis of the digitized signals and an output signal representative of such position is generated.

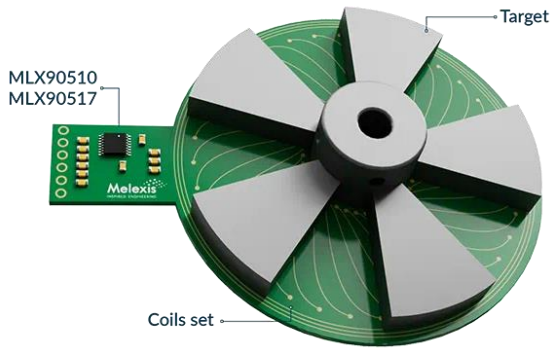

Figure 1. Inductive position sensor assembly

Fig. 1 provides an example of an inductive rotary position sensor equipped with a 5 lobes target, which determines its range to be $360^\circ/5 = 72^\circ$. Over this range, the sensor will output an angle varying from 0° to 360° . We therefore define 72° as one electrical period, spanning 360° electrical: $1^\circ = 5^\circ$ electrical. More generally, if N is the number of lobes of the target, $1^\circ = N^\circ$ electrical. Note also that other topologies are possible as well, like linear or arc sensors. This study focuses solely on the example of Fig. 1.

The Tx coil consist of a multiturn circular coil whose diameter and number of turns determines its inductance. The Tx coil is brought in resonance by means of a pair of capacitors whose value is selected to achieve a resonance frequency in between 2 and 5 MHz.

The Rx coils set is composed of three independent coils designed to produce a three-phase signal set that matches the periodicity of the target. The design of these coils is done according to the following approach:

1. **Primitive function definition (solid line, Fig 2a):** Define a primitive function that describes the basic path $p(\alpha)$ of the receiving coil represented as $r(\theta) = B + A \cdot \sin(\theta)$. Here, A and B are constants determined by system dimensions, and θ represents the angle ranging from 0 to 360° .

2. **Rx coil basic path definition (solid line, Fig 2b):** Project the primitive function into polar coordinates, adapting it to the sensor periodicity, as per formulas below:

$$x = p(N\theta) \cdot \cos(\theta)$$

$$y = p(N\theta) \cdot \sin(\theta)$$

3. **Tx-Rx coupling removal (dashed lines, Fig 2a and 2b):** The Rx coil as per the path defined above would exhibit non-zero coupling with the Tx coils. However, the objective is to achieve electromagnetic coupling only in the presence of the target. To accomplish this we connect in series the path already obtained with a second path. This path is an exact replica of the first path but rotated by 180° electrical, generating an opposite coupling and, consequently, overall zero coupling with the transmission coil.

4. **Complete the design (Fig 2c):** Replicate the Rx coil achieved above two times, shifting them by 120° electrical and 240° electrical to obtain the full set of Rx coils. Add the Tx coil and the target.

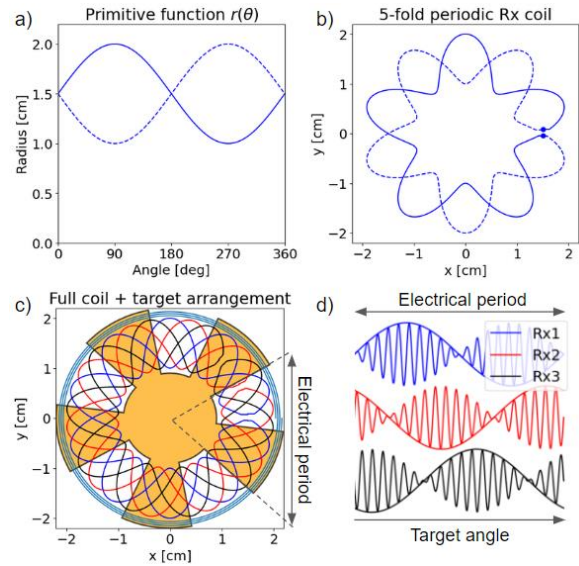

Figure 2. Inductive sensor design procedure.

When the target is present and the Tx coil is excited, each Rx coil produces an AC voltage signal whose amplitude is modulated sinusoidally as the target rotates, as depicted in Fig. 2d. The interface IC determines the target rotational angle from the amplitude of the three Rx coils signals.

COMSOL model implementation

The printed circuit boards (PCBs) for inductive position sensors are typically designed in CAD tools and exported in gerber or ODB++ format. With COMSOL, ODB++ files can be seamlessly imported using a specialized module known as the ECAD Import module. This feature simplifies the generation of the model geometry while at the same time accurately preserving all the details within the design. This ensures that the simulation does not introduce simplifications that could hide non-idealities in the sensor behavior. Fig. 3 illustrates the geometry of one of the sensors simulated.

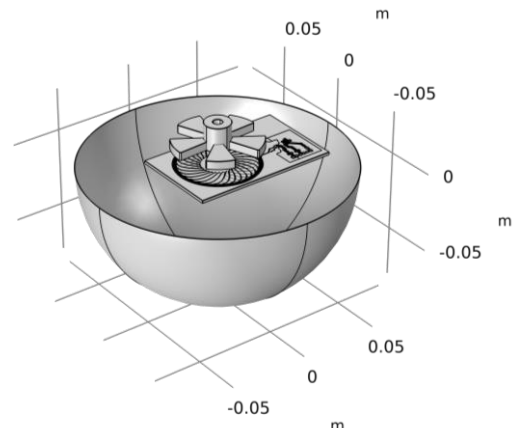

Figure 3. COMSOL model geometry.

Concerning selection of the physics module to be used for the electromagnetic simulations, the model dimensions have to be compared with the wavelengths at play. The transmission coil (Tx) is driven by a signal with an amplitude of 2.4V operating at a frequency approximately around 3MHz. Given this configuration, the dimensions of the coils (~5 cm) remain considerably smaller than the wavelength (~100m) and hence no radiative effects need to be considered. As a consequence, the AC/DC module within COMSOL is the optimal choice.

Within the AC/DC module, two sub-modules have been used to build the model physics:

- The Magnetic Fields Physics (mf) sub-module is used to define boundary conditions and specifying the operation of the different coils.
- The Electrical Circuit Physics (cir) sub-module is used to introduce in the model the IC related aspects, in particular the driving of the Tx coil and the input impedance to which the Rx coils interface to.

The foundational equations underpinning the inductive sensor principle are Ampere's law and Faraday's law. The passage of electrical current through the closed Tx coil gives rise to the generation of an induced magnetic flux density (Ampere's law). The alternating magnetic fields generated by the Tx coil will penetrate the metallic target. This penetration induces eddy currents within the conductor, giving rise to magnetic fields that oppose the excitation (Lenz's law). Notably, these eddy currents will predominantly remain on the surface, penetrating only for the skin depth δ :

$$\delta = \frac{1}{\sqrt{\pi f \mu_0 \mu_r \sigma}}$$

Within our system, operating at a frequency f of approximately 3 MHz and with a stainless-steel target with $\sigma = 1.45 \text{ MS/m}$, $\mu_r = 1$, the resulting skin depth measures 0.24 mm, considerably smaller than the target dimensions. Therefore, the target can be modeled by means of the impedance boundary approximation [5], simplifying considerable the meshing. Fig. 4 shows the surface current distribution on the target surface facing the coils as calculated by COMSOL.

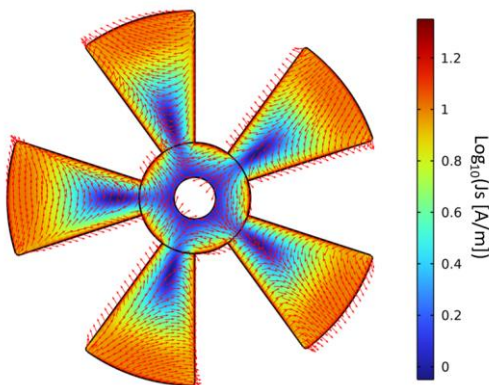

Figure 4. Target surface current distribution.

A similar argument holds for the PCB traces, which being made of Cu are associated with a skin depth of 34 μm , similar to their thickness (35 μm). For them, the transition boundary condition is used, since it is adapted to objects being geometrically but not electrically thin [5]. Once more, this brings a significant simplification of the mesh, as it allows importing the PCB traces as surfaces rather than volumetric elements.

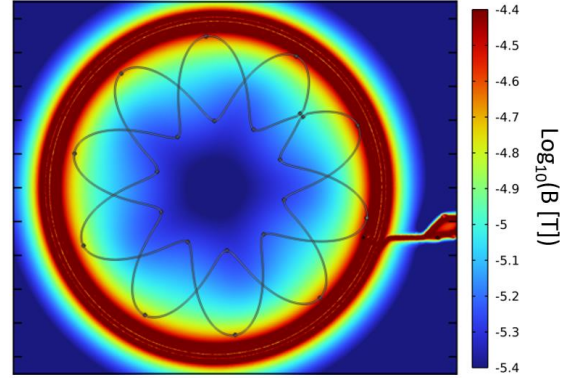

Figure 5. Coil plane magnetic field distribution.

Fig. 5 shows the simulated magnetic field in the coils plane. This field is the sum of the primary field and the target secondary field. The secondary magnetic fields are picked up by the Rx coils, inducing an electromotive force (voltage) within the coils, as per Faraday's law. The amplitude of the three voltages generated by the Rx coils (Rx1, Rx2, Rx3) constitute the output of the model. For a given sensor configuration, simulations are run with a target rotating at a constant pitch, which allows collecting data as the ones shown in Fig. 6.

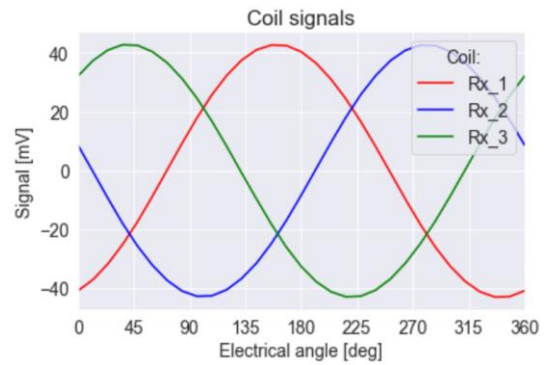

Figure 6. Simulated Rx coils signals amplitude vs. target position over one full electrical period

The study is repeated for different PCB to target spacings, which is realized via parametric sweeps. To speed up the model execution, the workload is parallelized by means of nested sweeps.

Simulation study

In an ideal realm devoid of mechanical or physical disruptions, the sensor as described in the previous section would provide an angle with negligible error. However, practical implementations are always affected by non-idealities. In particular, any metallic

part that does not belong to the Tx and Rx coil set core described previously, e.g. feeding wires used for connecting the coils to the IC, distribution of the coil over multiple PCB layers, PCB ground plane, eventual metals in close proximity to the coils ..., are likely sources of accuracy errors and their impact must be evaluated. In this study, we will focus on how COMSOL enables us to translate the influence of three factors on the accuracy of inductive position sensors:

- The number of layers of the PCB (2 or 4).
- Feeding wires connecting the Rx coils to the IC.
- Nearby metallic ground planes in proximity to the coils.

The approach taken is to start from an ideal sensor configuration and progressively introduce non-idealities. For each configuration tested, we apply the following protocol to determine its accuracy:

- Perform the simulations of the inductive design with different airgap between the coils and the target and record the Rx signals amplitude.
- Determine the angle calculated by the sensor by processing the Rx coils signals. This is done by applying a Clarke's transformation to the three Rx coils signals, followed by an arctangent calculation on the obtained I/Q values.
- Compare the calculated angle to the reference position of the target and get the accuracy.

This protocol makes it easy to link every modification of the PCB design to improvement or degradations of the system's accuracy. For the ideal case of Fig. 7, realized in a 4-layers PCB with 0.3 mm spacing in between the planes, the accuracy curve at each airgap is fairly flat, implying near-perfect accuracy over a rotation, see Fig. 8. The offset between the three curves is due to the change in airgap (PCB to target distance).

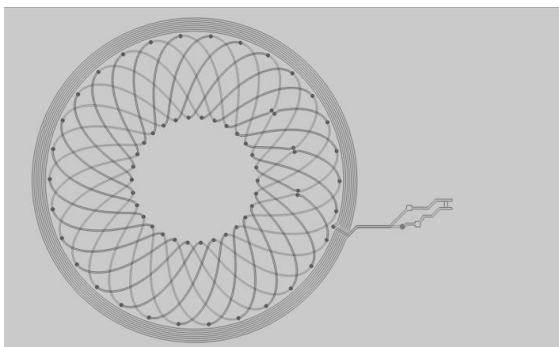

Figure 7. PCB design of an IPS in an ideal case - 4 layers

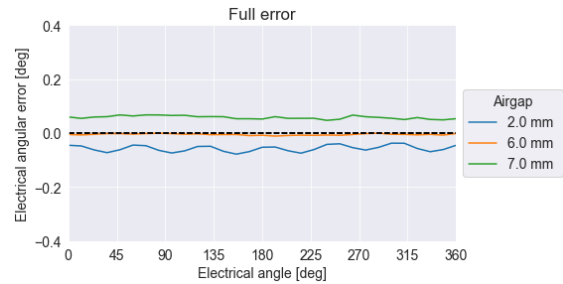

Figure 8. Sensor accuracy in ideal case - 4 layers

The first non-ideality we introduce is the ground plane (Fig. 9). This metallic ground plane, on top of which the IC and the passive components of the board are mounted, will host eddy currents that can influence the Rx coils signals. As expected, the addition of the ground plane to the PCB design modifies the error curve (see Fig 10). A 1st harmonic error is added on the top of the flat error. The closer the ground plane will be to the coils, the higher will be this 1st harmonic error that can be observed.

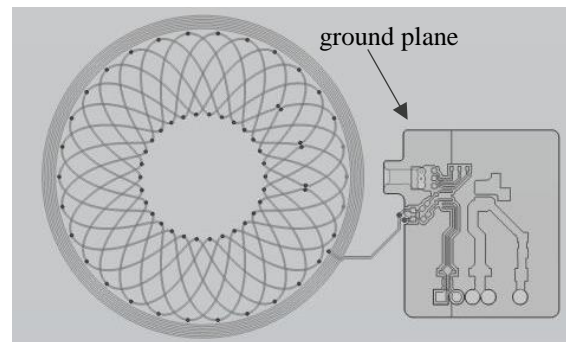

Figure 9. PCB design including a ground plane - 4 layers

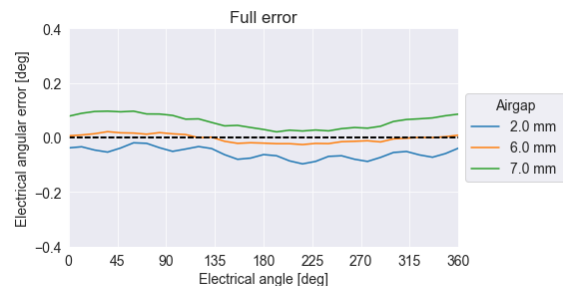

Figure 10. Sensor accuracy with ground plane - 4 layers

The three receiving coils must be connected to the IC of the inductive position sensor in order to be processed and output into analog or digital signals. To do so, the use of copper wires that run through the PCB to the IC inputs is mandatory. However, as for the ground planes, the copper wires are metallic traces distributed on two planes, which leaves parasitic surfaces that capture magnetic fields emitted by the Tx coil. Two configurations are available for connecting these receiving coils to the IC. In the first case the feedings connections are separated by 60° electrical (Fig. 11), in the second by 120° electrical (Fig. 13). The corresponding error curves are shown in Fig. 12 and 14, respectively.

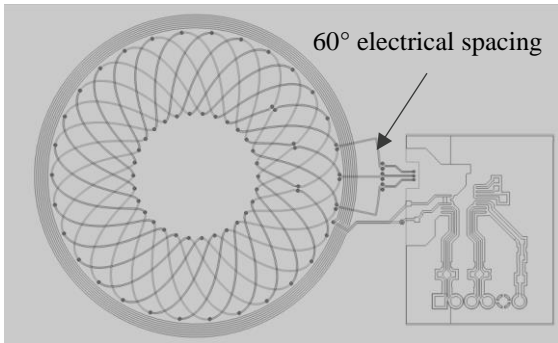

Figure 11. PCB design with 60° electrical feedings configuration – 4 layers

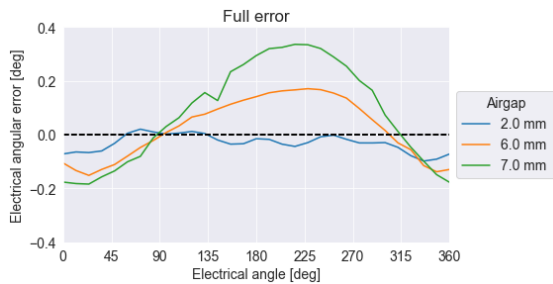

Figure 12. Accuracy with 60° electrical feedings – 4 layers

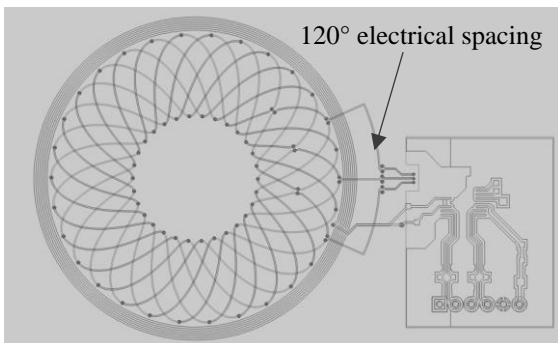

Figure 13. PCB design with 120° electrical feedings configuration – 4 layers

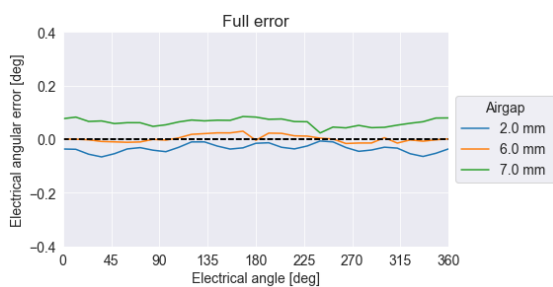

Figure 14. Accuracy with 120° electrical feedings – 4 layers

The results of Figs. 11 to 14 clearly indicate the superiority of the 120° electrical spacing.

The same study has been repeated on 2 layers PCB designs, where the PCB planes are spaced by 1.6 mm, significantly more than in the 4-layer case. The results are summarized in Figs 15 and 16 for the 60° electrical feeding spacing case and Figs 17 and 18 for the 120° electrical feeding spacing case. In the two-layer configuration, non-negligible errors arise in both cases. This occurs because the feeding lines need to pass below the Tx coil via one plane only,

generating horizontal parasitic surfaces that could be avoided in the 4-layers configuration, where the feedings lines could be stacked systematically over their whole length, generating only small vertical parasitic surfaces.

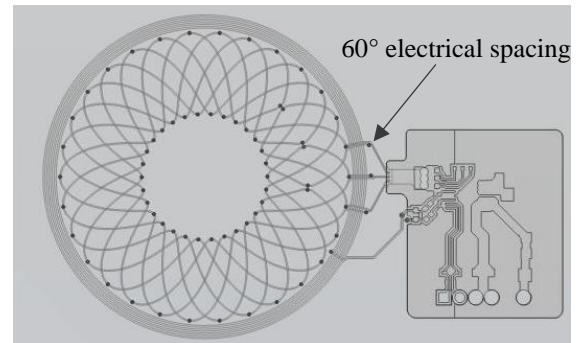

Figure 15. PCB design with 60° electrical feedings configuration – 2 layers

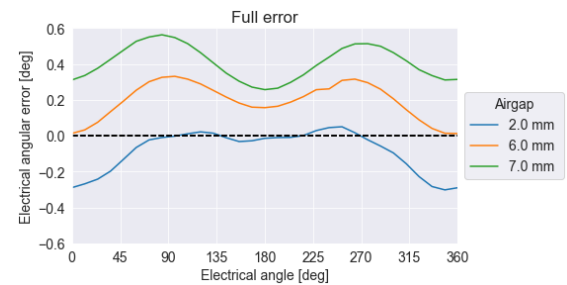

Figure 16. Accuracy with 60° electrical feedings – 2 layers

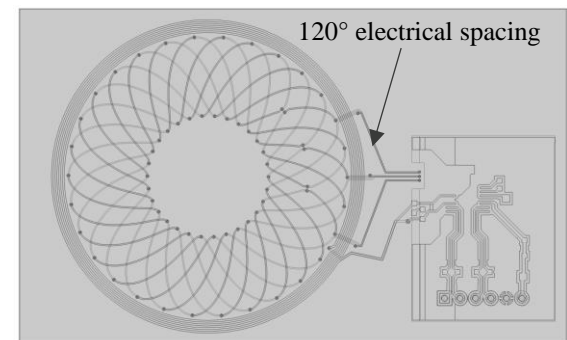

Figure 17. PCB design with 120° electrical feedings configuration – 2 layers

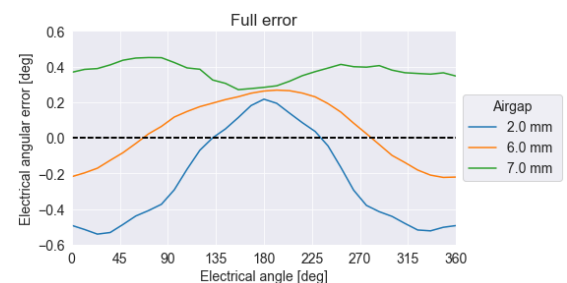

Figure 18. Accuracy with 120° electrical feedings – 2 layers

Conclusions

This paper explored inductive position sensors and the influence of layout non-idealities on their performance.

By means of COMSOL simulations, we studied the factors influencing the accuracy of a reference design, with a special emphasis on PCB layout features. The COMSOL ECAD Import and the AC/DC modules allowed us to create accurate models of the sensor system.

Through simulations, we investigated the impact of various design parameters on sensor accuracy, including the number of PCB layers, wire connections (feedings) to the interface IC, and the presence of nearby metallic ground planes. We found that these factors are sources of inaccuracies. The addition of a metallic ground plane introduces a 1st harmonic error, while variations in electrical phase separation in feedings connections impacted accuracy, with 120° electrical spacing between the feedings providing optimal results.

We also explored the challenges of two-layers PCB configurations, where layout constraints lead to design affected by generally higher errors with respect to 4-layers designs.

References

- [1] W.Granig,S.Hartmann,B.Köppl, "Performance and Technology Comparison of GMR versus commonly used Angle Sensor Principles for Automotive Applications", SAE Technical Paper 2007-01-0397, 2007
- [2] L.Lugani, Y. Akermi, P.Laval, A. Duisters, "High speed inductive position sensor for E-machines", *Melexis*, 2021
- [3] Melexis MLX90510, "High-Speed Inductive Resolver with Analog Output", in <https://www.melexis.com/product/MLX90510>
- [4] Melexis MLX90517, "High-Speed Inductive Resolver -analog (off-chip calculation)", in <https://www.melexis.com/product/MLX90517>
- [5] Comsol, "The AC/DC Module User's Guide", in <https://doc.comsol.com>

Acknowledgements

We would like to acknowledge Yassine Akermi for the help provided in the generation of the layouts.