

Energy Generation Using Piezoelectric Crystal

Akshay Deshpande¹, Sujata Naduvinamani²

Department of Instrumentation technology engineering
B.V.Bhoomaraddi college of engineering and
Technology,Hubli,Karnataka,India

akshayd91@gmail.com¹, sujatanaduvinamani@gmail.com²

ABSTRACT: *The present times demand for the use of eco-friendly and renewable sources of energy. With the rising fear of ending non-renewable energy sources along with the damaging effects that they pose to the environment, this sort of approach is of utmost importance. This has also led to the search for alternate methods of transforming the various forms of energy from one form to other, especially into electrical form. Popular renewable energy sources such as hydropower, solar power and wind power require massive financial investments, and have a low scale of efficiency. Nuclear power offers a cleaner source of energy and provides greater efficiency, however it being costlier & hazardous than other known energy sources. The recent era demands for an alternative such as conversion of energy into electrical form. The most effective among them being the conversion of mechanical energy into electrical energy. Piezoelectric materials are by far, one of the most efficient elements to accomplish this task. Piezoelectric materials convert mechanical energy into deformation thereby producing charge deposition (hence voltage). They have, however, been mostly used for applications with a low power generation, in the range of micro-watts to milli-watts. Analysis on piezoelectric material to generate electricity is done by using MEMS simulation tool called COMSOL MULTIPHYSICS. By varying the parameters analysis is done and graphs have been plot.*

Keywords: PZT, piezoelectric effect, COMSOL, simulation, and modelling.

I. INTRODUCTION:

The main concentration here is on the generation of the electrical energy from the piezoelectric material. Quartz, lithium zirconate titanate and piezo-ceramic materials suit this application. We can generate energy by using conventional method, but there is lot of difference in conventional method and by using MEMS technology .Power generation is very low in case of conventional methods like Euler Bernoulli methods of generating electric power . Now a day's most of the devices

have become portable due to the MEMS technology. So MEMS technology is preferred almost in all fields. By using MEMS tool power can be generated in terms of micro volts to milli-volts. New technology allows for these appliances to reduce overall in size but battery dimensions remain the same. An alternative for batteries is to create energy using piezo-ceramic materials. These smart materials can convert mechanical strain to electrical energy i.e. voltage.

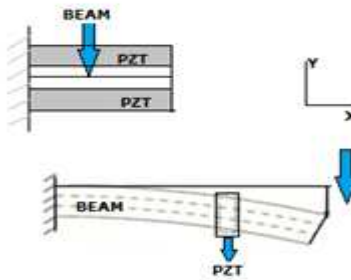

Figure 1: Simplified demonstration of the piezoelectric effect

Key factors involved in the amount of energy produced by a piezoelectric material have to do with the stress on the element that is the ratio of the applied force to the surface area of the element. Very high amounts of electric energy are obtainable with piezoelectric elements when the amount of stress applied to it is very high or very frequent.

II. LITERATURE SURVEY

The designed model works on the principle of piezoelectric material. Modelling the PZT sensor using the Euler Bernoulli method. The Euler Bernoulli model is the most accurate. The PZT and substrate both bend about a common neutral axis which is no longer the neutral axis of the beam. Perfect bonding is assumed, and the PZT is considered to be a layer of the beam. This neutral axis is calculated by a modulus-weighted algorithm.

In [1] paper the author deals with the different ways of generating electric voltage by applying pressure on the cantilever beam. The paper explains the classic theory and the modern Euler-Bernouli's model of generating the voltage from PZT. In [2] paper the authors describe how the thin film can be used as the transducer to generate the voltage from the piezoelectric devices. Also an array of lead zirconate titanate (PZT) thick-film cantilevers were designed and fabricated to demonstrate the possibility of harvesting vibration energy from different frequencies. In [3] paper the author explains the basic theoretical modelling of the electrical power generation mechanisms and optimization of the piezo system. It is shown that with proper configuration, a single piezo -film can generate enough electrical density that can be stored in a rechargeable battery for later usage. In [4] paper, the dynamics of piezoelectric materials for the use of power generation devices has been experimentally investigated. The objectives of this work are to estimate the amount of power that PZT can generate, and to identify the feasibility of the devices for real-world applications. In [5] paper the author gives the explanation about the need for alternate energy resources, different ways of generating the energy and the importance of piezoelectric energy harvesting.

III. MATHEMATICAL MODEL

The design consists of a piezoelectric block (quartz crystal) enclosed within an aluminium block. The pressure is applied to this crystal to generate the required output that is the voltage.

The equations involved in the calculation are:

$$V = g \cdot t_b \cdot \text{stress} \quad (1)$$

Where,

V=output voltage, g=voltage constant,
 t_b =thickness of the aluminium block (constant:
width=0.1mm, depth=0.03mm, height=0.018mm)

Stress applied to the piezoelectric Crystal is given by the equation:

$$\text{Stress} = E \cdot \text{strain} \quad (2)$$

Where, E=Young's modulus = 62G

The strain on the crystal is:

$$\text{Strain} = \frac{\text{change in crstal length}}{\text{original length}} \quad (3)$$

Change in length is the range over which the length of crystal is varied and the original length is the length of the aluminium block.

B. MATLAB SIMULATION

Mathematical equations are simulated and verified using MATLAB software.

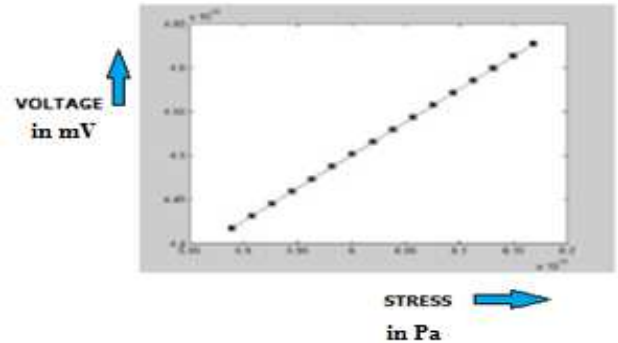

Fig3. Stress vs. voltage

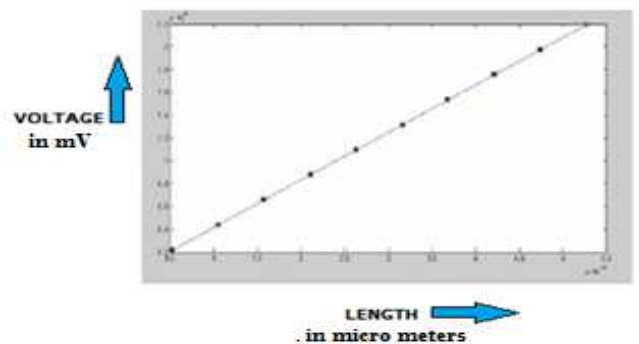

Fig. 4 Length vs. voltage

IV. PROPOSED DESIGN AND ITS SIMULATION

This paper deals with the simulation of energy generator using MEMS tool. The design comprises of two blocks of Aluminium and quartz crystal. The dimensions are taken either in mm or in μm . The dimensions of the Aluminium block are fixed Whereas the length of the piezoelectric crystal is varied accordingly. This model gives the measurement of voltage based on the applied pressure that is the change in the length of piezoelectric crystal. The energy generator is designed using COMSOL-Multiphysics software. The process carried out in COMSOL is as shown in below figures:

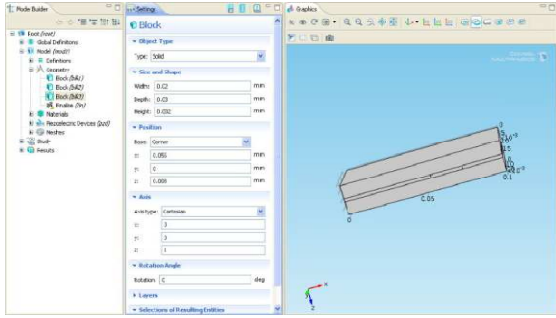

Fig5. Process editor

The shear actuated beam performs a static analysis on a piezoelectric actuator based on the movement of a cantilever beam, using piezoelectric devices. 3D model can be built using COMSOL Multiphysics work window by defining the necessary parameters.

Following snaps represent the 3D layout the proposed model

The basic block models a sandwich beam using the shear mode of the piezoelectric material to deflect the tip.

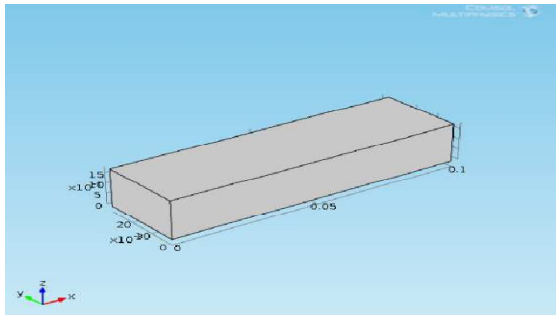

Fig.6 3D model of Aluminum block with the fixed parameters (length, thickness and height)

The model consists of a well defined sandwiched cantilever beam. This beam is compressed of a thick flexible FOAM core sandwiched by two thick ALUMINIUM layers. Further the device includes a piezo –actuator positioned suitably.

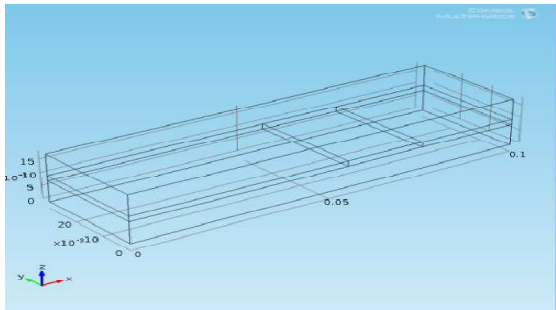

Fig.7 Depicts the aluminium and the quartz blocks(modules)

The dimensions & the properties of the materials which are added are decided and the model is meshed in tetrahedral blocks as shown below:

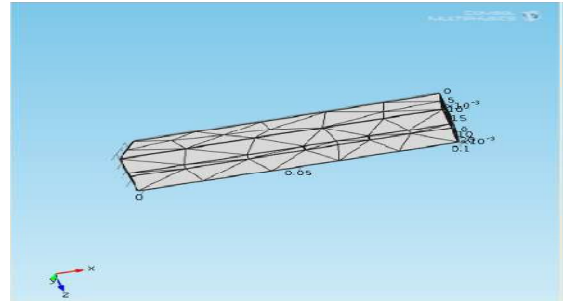
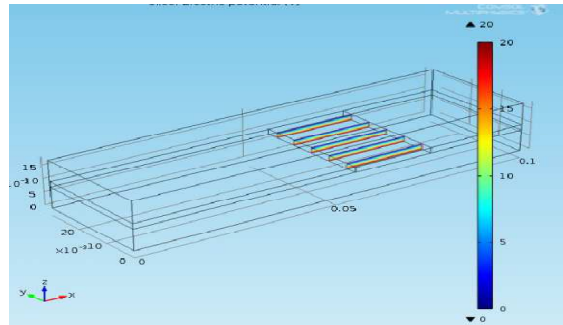

Fig.8 Meshing

The results (that is the beam displacement or the induced voltage) are obtained by clicking the plot button.



Fig,9 Quartz crystal after displacement

The shear deformation of the piezo-layer and the flexible foam layer induce a bending action and produce the voltage.

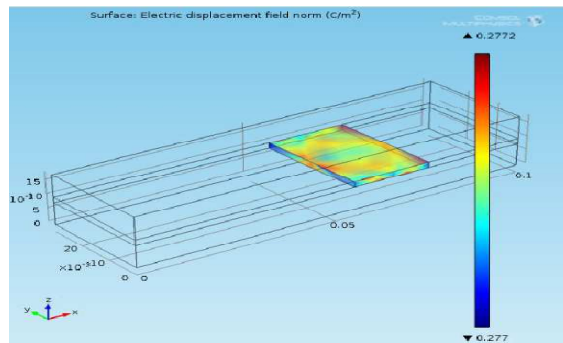

Fig.10 Quartz crystal after displacement

V. CALIBRATION:

The basic material properties required for the model are selected in the model wizard. The shape & dimensional settings regarding the block are done in geometry window, where different parameters related to shape and size are decided.

The materials can be included in the model from the material browser and model library. The thickness and breadth of the

Quartz crystal is kept constant:

Breadth = 0.03mm, Thickness = 0.002mm

Table I

Models	Crystal length in milli-meter	Voltage milli volt
MODEL 1	0.003	5.91
MODEL 2	0.0045	7.34
MODEL 3	0.005	7.78
MODEL 4	0.008	11.27
MODEL 5	0.01	15.19
MODEL 6	0.02	24.85
MODEL 7	0.03	33.42
MODEL 8	0.035	41.16
MODEL 9	0.04	48.22
MODEL 10	0.045	53.35

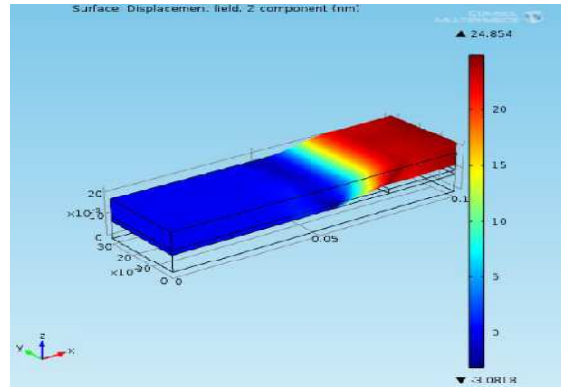

Fig.11 Final outcome (MODEL-1 from the table)

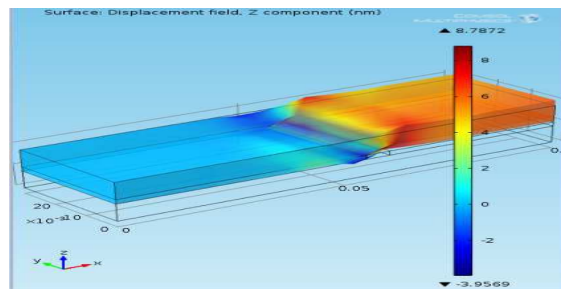

Fig.12 Final outcome (MODEL-4 from the table)

Table II

x	y	z	Value
0.0015	0.01011	0.018	3.3700e-4
0.00508	0.00924	0.018	0.00101
0.00765	0.00822	0.018	0.00164
0.01068	0.00959	0.018	0.00486
0.01452	0.0104	0.018	0.01029
0.01961	0.01123	0.018	0.02554
0.02293	0.01016	0.01801	0.02011
0.0284	0.00937	0.018	0.00437
0.0344	0.00957	0.01803	0.19443
0.03943	0.01005	0.01807	0.41216
0.04499	0.01004	0.01804	0.21585
0.04978	0.01018	0.01782	-1.02452
0.05549	0.01069	0.01813	0.75186
0.06009	0.01003	0.01895	5.31566
0.06515	0.01058	0.02023	12.47223
0.06962	0.01132	0.02118	17.79969
0.07404	0.01129	0.02181	21.34188
0.08154	0.01174	0.02215	23.27694
0.08821	0.01463	0.02221	23.60376
0.09314	0.01567	0.02228	23.98493
0.09804	0.01595	0.02235	24.38239
0.09906	0.01747	0.02242	24.76998
0.0998	0.01641	0.02242	24.76704

From the table,

x=length of the Aluminium Block
 y=width of the whole system
 z=height of the whole system
 value=corresponding output voltage

VI. RESULT AND DISCUSSION:

The results obtained after simulation are as follow:

The BLUE region indicates that there is no pressure being applied and the RED region indicates that there is maximum pressure being applied. The central band is the quartz crystal.

VII. CONCLUSION:

Energy generator is designed using MEMS tool using COMSOL MULTIPHYSICS software. The Graphs of stress vs. voltage and Length vs. voltage are plotted in Outcome (Model1) COMSOL-Multiphysics Responses are observed as follows:

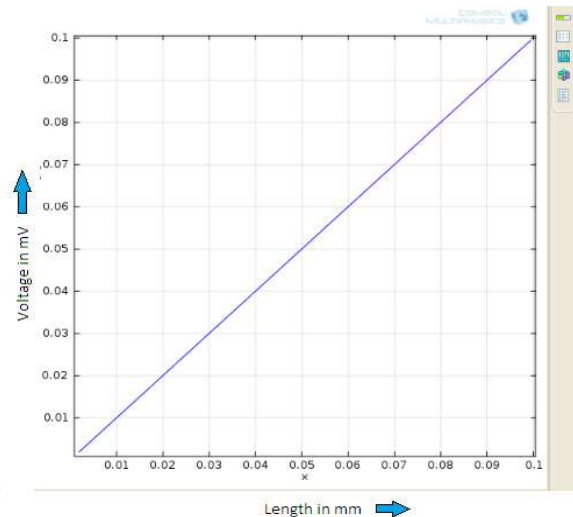

Fig.13 Graph depicting length vs. voltage in COMSOL

The results can be verified on graph by including the various X, Y and Z coordinates.

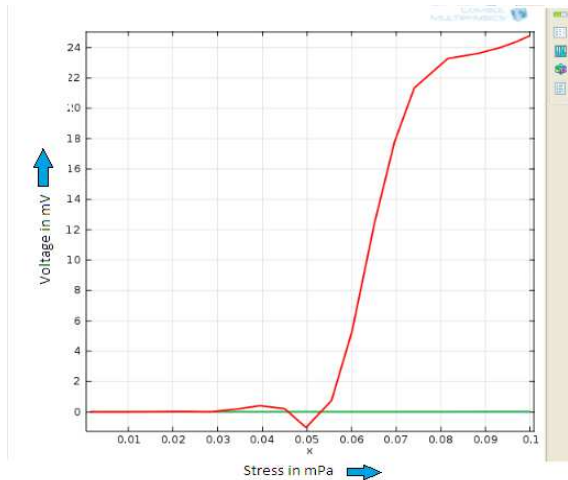

Fig.14 Graph depicting stress vs. Voltage in COMSOL

ACKNOWLEDGEMENT

The analysis work was supported by Dr. Vaishali B M., The HOD of the instrumentation Technology department and Ms. Sujata N., lecturer of Instrumentation technology B V Bhoomaraddi College of Engineering and Technology, Hubli.

REFERANCES:

[1] Timothy Eggborn, "Analytical Models to Predict Power Harvesting with Piezoelectric Materials" Thesis submitted to Virginia Polytechnic Institute and State University.

[2] Swee- Leong, Kok1*, Norizan Mohamad1, David Fook Weng, Yap1, Soo Kien, Chen2, Chang Fu, Dee3, "Multi-Frequency Energy Harvesting Using Thick-Film Piezoelectric Cantilever", This paper appears in: Electrical, Control and Computer Engineering (INECCE), 2011 International Conference, Pahang

[3] Jedol Dayou, Man-Sang, C., Dalimin, M. N. & Wang, S, "Generating electricity using piezoelectric material". This paper appears in BORNEO SCIENCE 24: MARCH 2009

[4] Henry Sodano, Elizabeth A. Magliula, Gyuhae Park, Daniel J. Inman. "ELECTRIC POWER GENERATION USING PIEZOELECTRIC DEVICES" This paper appears from Center for Intelligent Material Systems and Structures, Virginia Polytechnic Institute and State University, Blacksburg, VA 24061, USA

[5] Henry A. Sodano, Daniel J. Inman, Gyuhae Park. "A Review of Power Harvesting from Vibration using Piezoelectric Materials" *The Shock and Vibration Digest* / May 2004